

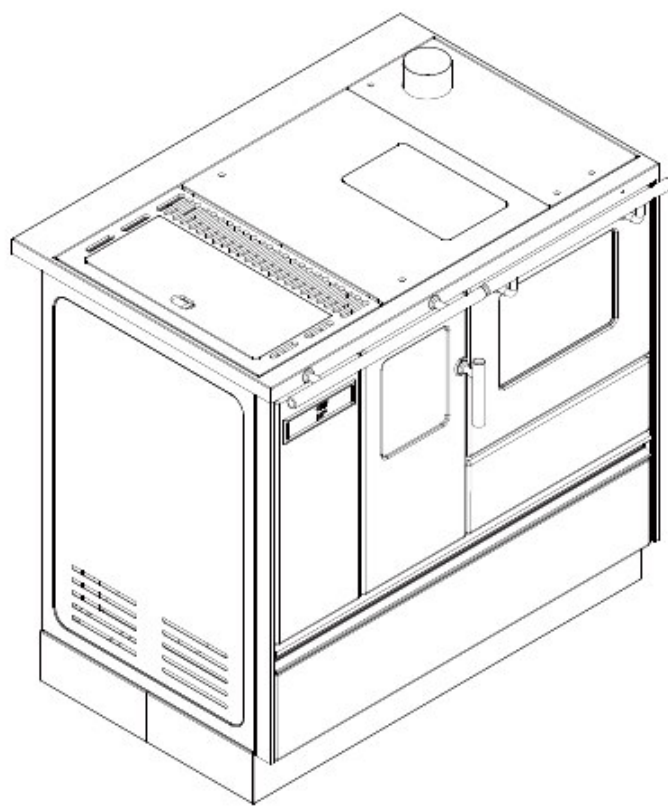

USER MANUAL ALFA 90 PELET



Ecological burning stove that heats your home

ALFA PLAM

Heating appliances (hereinafter referred to as "stove") of ALPHA PLAM are constructed and their technical acceptance test was performed on the basis of safety regulations stated in the referent European Union directives.

This manual is intended for owners, installers, workers and staff responsible for stoves maintenance.

In case of any doubt, and for all clarifications, please contact the manufacturer or authorized service, and specify the number of the disputed paragraph.

Printing, translation and reproduction, even partial, of this Manual must be authorized by ALFA PLAM Company.

Technical information, graphics and specifications in this Manual may not be published.

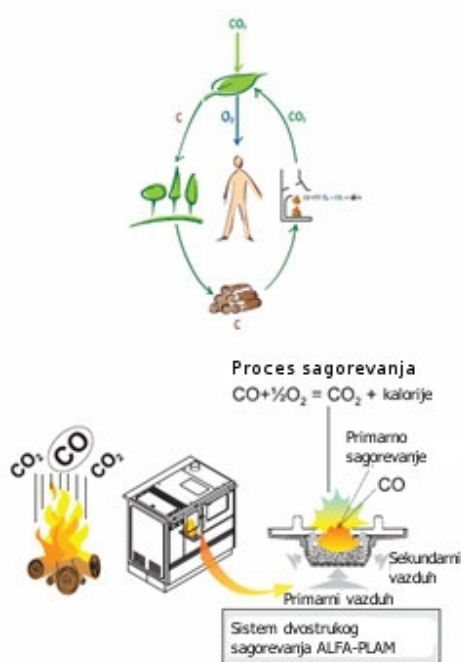

DOUBLE COMBUSTION SYSTEM

Flame produced by wood that is properly burning in a stove emits the same amount of carbon dioxide (CO₂) that is released due to the natural decomposition of the wood itself.

The amount of CO₂ produced as a result of combustion or decomposition of a plant, is equal to the amount of CO₂ that the plant itself can take from the air and convert into oxygen, which is released into the air and into the carbon it consumes during its life cycle.

Using non-renewable fossil fuels (coal, oil, gas), unlike to what happens with the wood, releases into the air large amounts of CO₂, accumulated over millions of years, increasing the greenhouse effect. However, the use of wood as fuel is in perfect balance with nature since it uses renewable fuels, which is in conformity with the environmental cycles of nature.

The principle of clean combustion is fully compliant with the objectives and the firm ALFA PLAM took care about it when designing its products.

What do we mean by clean combustion and how do we achieve this? Control and regulation of primary air and secondary air insertion leads to the second combustion, that is to post combustion characterized by a second, stronger and lighter flame that develops above the main one.

That flame, thanks to the introduction of a new oxygen combusts gases significantly by improving performance and reducing heat to a minimum emission of harmful CO (carbon monoxide) generated due to incomplete combustion. This is an exclusive feature of the stoves and other products of the company ALFA PLAM.

TABLE OF CONTENTS

1	INTRODUCTION	7.	PUTING INTO OPERATION AND USING OF THE STOVE
1.1	SYMBOLS	7.1	PELLET LOADING
1.2	PURPOSE	7.2	CONTROL PANEL DESCRIPTION
1.3	PURPOSE AND CONTENTS OF THE MANUAL	7.3	START UP PHASE
1.4	STORING MANUAL	7.3.1	Electric Power
1.5	UPDATING OF THE MANUAL	7.3.2	Phase of work (ignition)
1.6	GENERAL INFORMATION		
1.7	GENERAL PROVISIONS RELATING TO PREVENTION OF ACCIDENTS AT WORK AND THOSE THAT HAVE TO BE OBSERVED	7.4	WORK PHASES
1.8	STATUTORY WARRANTIES	7.5	SWITCHING OFF PHASES
1.9	MANUFACTURER'S ACCOUNTABILITY	7.6	ADVANCED USE OF THE CONTROL PANEL
1.10	CHARACTERISTICS OF THE USER	7.6.1	Clock
1.11	TECHNICAL ASSISTANCE	7.6.2	Timer
1.12	SPARE PARTS	7.7	ALARMS
1.13	IDENTIFICATION TABLE	7.7.1	Alarm Alar ACC (ignition alarm)
1.14	STOVE DELIVERY	7.7.2	Cool Fire Alarm (Alarm to stop AC power)
		7.7.3	Alarm Alar Sond (Alarm probe to smoke)
2	SAFETY RULES	7.7.4	Alarm Alar DEP (Alarm for depression)
2.1	WARNINGS FOR INSTALLING	7.7.5	Alarm Alar PELL (Alarm for pellet temperature)
2.2	WARNINGS FOR USERS	7.7.6	Alarm Alar Fan (Alarm for the air induction fan)
2.3	WARNINGS FOR MAINTENANCE WORKERS	7.7.7	Alarm Alar hot (alarm for the high smoke temperature)
		7.7.8	Alarm Fire Alar (Alarm for fire extinction during the phase of work)
3	SPECIFICATIONS AND DESCRIPTION OF FUEL AND STOVE	7.7.9	Alarm Alar Sic (Alarm for the main thermostat)
3.1	CHARACTERISTICS OF FUEL		
3.2	STORAGE OF PELLET	8	MAINTENANCE AND CLEANING
3.3	DESCRIPTION OF THE MAIN PARTS OF THE CABINET	8.1	SAFETY MEASURES

		8.2	REGULAR MAINTENANCE BY THE USERS
4	DELIVERY AND TRANSPORT	8.2.1	Interior cleaning of furnace
		8.2.2	Cleaning ashtray
5	PREPARING SPACE FOR INSTALLATION	8.2.3	Glass cleaning
5.1	PRECAUTION MEASURES	8.2.4	Chimney Cleaning
5.2	GENERAL MEASURES	8.2.5	Setting of the lever
5.3	PLACE FOR INSTALLING THE STOVE		
5.4	AIR USED FOR COMBUSTION	9	INFORMATION ON THE DESTRUCTION AND TRANSPORT TO LANDFILL
5.5	SMOKE DISCHARGE		
5.5.1	Pushing the smoke up the chimney onto the roof	10	ELECTRIC SCHEME
6	INSTALLATION		TECHNICAL SPECIFICATIONS
6.1	LEVELLING THE STOVE		
6.2	CONNECTING THE APPLIANCE		
6.2.1	Connecting to the power supply		
6.2.1.2	Commissioning		

Dear Customer,

First of all, we wish to thank you for the trust you have placed in us by purchasing our product and we congratulate you on your choice.

To make sure that you use your new stove in the best way, we advise you to read this manual carefully.

1 INTRODUCTION

Do not do anything if you have not understood all the information outlined in the manual; in case of any doubt, seek assistance from specialized staff of ALFA PLAM company.

ALFA PLAM reserves the right to change at any time the specifications and technical and / or functional characteristics of the stove, without prior notice.

1.1 SIMBOLS

In this manual, very important items are highlighted with the following symbols: .

DANGER: This symbol expresses a significant remark about the behavior in order to prevent accidents or damage to materials



INSTRUCTION: Instruction regarding the proper use of the stoves and the responsibility of the authorized persons



ATTENTION: An item that is of great importance.



DANGER: This symbol expresses a significant remark about the behavior in order to prevent accidents or damage to materials

1.2 PURPOSE

!

The ALFA PLAM unit is a new stove for heating, with its advanced technology, which only uses pellets and thanks to automatic operation creates a healthy and safe heat in space.

The Stove shall work exclusively with a sealed combustion chamber door.

Do not open the door when the stove is operating.

The stove is characterized by a double combustion system: PRIMARY and SECONDARY with positive effects in terms of performance and in terms of discharge of the "cleaner smoke."

The above purpose and the designed configuration of the stoves are the only ones allowed. Manufacturer: **never use the stove in non compliance with the submitted guidelines.**

!

The above stated purpose is valid only for the devices with the complete structural, mechanical and installation efficiency. ALFA PLAM stove is a device for indoor space only.

1.4 STORING MANUAL

STORING AND CONSULTATION

The manual must be carefully stored and must always be available for consultation, both from the users, as well as by the staff responsible for installation and maintenance.

Manual - *Instructions for use and maintenance* is an integral part of the stove.

DESTRUCTION OR LOSING

If necessary, ask the company ALFA PLAM for another copy.

ASSIGNMENT OF THE STOVES

In case of an assignment of the stove, the user is required to submit a new customer with this manual.

1.6 GENERAL INFORMATION

INFORMATION

In case of exchange of information with the manufacturer of the stoves, it is necessary to specify the serial number and identification data listed on the page "GENERAL INFORMATION" at the end of this manual.

RESPONSIBILITY

By submitting this manual, ALFA PLAM company is exempted from any responsibility, both civil and criminal, in case accidents caused by partial or total disregard of specifications listed therein.



In addition, ALFA PLAM company is exempted from any responsibility in case of nondesignated or improper use of stove by the user; in case of unauthorized modifications and / or repairs, in case of use of non-original spare parts or those that are not designed for this model of the stove.

EMERGENCY MAINTENANCE

Extraordinary maintenance must be performed by qualified personnel trained to intervene on the model stoves referred to in this manual.



ACCOUNTABILITY FOR ACTIONS DURING INSTALLATION

Responsibility for actions taken when installing the stove cannot be assigned to ALFA PLAM, company but responsibility goes, and remains, with an installer, who is required to

conduct checks as for the chimney and bringing of air, as for properly proposed installation solutions. In addition to that, all safety regulations and applicable special legislation of the state in which the stove is being installed have to be complied with.

USE

Except for the regulations listed in this manual, using the stove is to be in line with all applicable safety regulations provided for by special legislation of the state in which the stove is installed.

1.8 LEGAL GUARANTEE

To be able to use the legal guarantee in accordance with EEC Directive 1994/44/CE, the user has to strictly abide by the guidelines contained in the manual hereof, the user is to, in particular:

- use the stove within the stipulated limits;
- regularly and carefully maintain the stove;
- for the use of the stove, authorize persons of proven ability, behavior and those adequately trained for this purpose.

Failing to comply with the information given in this manual shall lead to the loss of warranty.

1.9 MANUFACTURER'S RESPONSIBILITY

! MANUFACTURER'S RESPONSIBILITY

Manufacturer is exempted of any civil and criminal accountability, direct or indirect, in the case of:

- *Installation which is not in accordance with the applicable regulations in the State with the safety recommendations;*
- *Not following the instructions contained in the manual;*
- *Installation which is performed by unqualified and unskilled staff;*
- *Usage which is not in accordance with safety recommendations contained in this manual;*
- *Performed modifications and repairs for which the user has not obtained the authorization from the Manufacturer;*
- *Using of spare parts or those that are not specific to this model of stove;*
- *Non-maintenance of the stove;*
- *Extraordinary events.*

1.10 REQUIRED CAPABILITIES OF THE USER

User of the stove is an adult, a responsible person with the technical knowledge necessary for routine maintaining of mechanical and electrical parts of the stove. Make sure that children do not approach the stove that is turned on, in order to play.

11.1 TECHNICAL ASSISTANCE

ALFA PLAM company is able to solve any technical problem related to usage and

maintenance of the stove, throughout its lifetime.
Central office is at your disposal so as to refer you to your nearest qualified service facility.

1.12 **SPARE PARTS**

Use only original spare parts.

Do not wait for the parts to wear out from use before replacing them.

Replacement of the seedily parts before the breaking leads to prevention of accidents that occur because of sudden breakage of parts, which can harm people and cause damage to property.



Carry out periodical inspections on maintenance as specified in the "MAINTENANCE AND CLEANING" chapter

1.13 **NAMEPLATE**

The main nameplate affixed to the stove contains all the characteristics of the product, including information on the manufacturer, identification number and CE mark.

1.14 **DELIVERY OF THE STOVE**

The stove is delivered in perfect packaging in a cardboard box. Attached to the wooden base which enables its movement with the help of forklifts and/or other means.

Inside the stove there is following material:

- Manual for usage, installation and maintenance;
- Spatula for cleaning the stove (channel through which the smoke flows).

2 **SAFETY WARNINGS**

2.1 **WARNINGS FOR INSATLLER**



- Make sure the specifications for the reception of the stove are in accordance with the local, national and European regulations.
- Adhere to the guidelines from this manual.
- Make sure the specifications of the of chimney and equipment for taking air are in accordance with the required type of installation
- Do not carry out bare electrical connections with temporary and non-insulated cables
- Check whehether the grounding of electrical devices is efficient.
- Always use the means for personal protection and other protective equipment as provided by law

2.2 **WARNINGS FOR USER**



- Prepare the space needed to install the stove in accordance with the local, national and European regulations.
- Because it is a heating device, the stove has very hot outer surfaces. It is therefore recommended to use extreme caution during work, and in particular:
 - Do not touch and or approach the glass door which may cause burns;
 - Do not touch the pipe through which the smoke flows;
 - Do not perform any cleaning;
 - Do not open the door with glass;

- Make sure that the children do not approach the stove;
- Adhere to the guidelines contained in this manual.
- Keep to the guidelines and warnings from the plates affixed to the stove.
- On the plates, there are guidelines for preventing accidents at work, so they must always be fully readable. If they are damaged or become illegible, they must be replaced, requests the Manufacturer to provide an original replacement.
- Use only the fuel in line with the guidelines from the chapter relating to the the fuel characteristics.
- Strictly adhere to the plan for regular and emergency maintenance.

- Do not use the stove without daily control performed as specified in the "Maintenance" chapter of this manual.
- Do not use the stove in case of malfunction, in case of doubt that something is broken or in case of unusual sounds
- Do not throw water on the stove in operation, or for the purpose of extinguishing the flame in ember tray.
- Do not extinguish stove by disconnecting the plug from the socket.
 - Do not lean over an open stove, it can endanger its stability.
 - Do not use the stove as support or for of any kind of anchoring
 - Do not clean the stove before completing cooling down of its structure and ashes.
 - Touch the door only when the stove is cold
 - Conduct all the operations calmly and in the conditions of maximum safety.
 - In the case of fire in the chimney, turn off the stove in the manner described for extinguishing described in the chapter 7.
 - In case of the poor operation of the stove caused by a week draft of the chimney, the same should be cleaned by applying the procedure described in 8.2.5. In any case, the cleaning of the chimneys should be conducted at least twice a year, in accordance with the guidelines from the article 8.2.5.
- Do not touch the painted parts during the stove operation of, so that the damaging of the colour can be avoided.
- Replacement of the fuse is done by qualified personnel.

ATTENTION: In order to avoid any danger caused by accidental plug in thermal switch, this stove should not be supplied through a device with exterior control, such as timer, but it should be connected to the circuit that is regularly supplied and disconnected from the network.

2.3 WARNINGS FOR MAINTAINANCE WORKER

- !** - Abide to the guidelines from this manual.
- Always use means for personal protection and other protective devices.
- Before beginning with any sort of maintenance, make sure that the stove, in case it has already been used, has cooled down.
- In case that any safety device is not working, it is considered that the stove is not working.
- Pull out the plug in from the socket on the wall before

work on electrical, electronic parts and connectors.

3 CHARACTERISTICS OF FUEL AND STOVE DESCRIPTION

3.1 FUEL CHARACTERISTICS

- Pellets or wooden rollers (Figure 3.1) is a mixture of different kinds of wood compressed by mechanical procedures observing environment protection regulations

It is the only kind of fuel prescribed for this kind of stove.

- Efficiency and thermal power of the stove can vary in accordance with the kind and quality of the used wooden rollers.

In order for the stove to work correctly, it demands rollers with the following characteristics:

- dimensions \varnothing 6 – 7 mm
- maximum length 30 mm
- maximum content of the humidity 8% do 9%

- The stove is equipped with the storage for wooden rollers with the capacity depicted in the above stated column of characteristic data.

The door for loading are placed on the upper side.



- **The cover can always be opened so that loading with the wood rollers can be conducted.**



For resetting of the control at the working temperature it is not possible to use the classical fuel.



It is forbidden to use the stove for incineration.



Fig.3.1

3.2 PELLET STORAGE



Pellets should be kept in a dry, not too cold space.

It is recommended that a couple of sacks with pellets should be kept in a room in which the stove is used or in an adjacent room because of the acceptable temperature and air

humidity.

Moist or/and cold pellets (5°C) reduce the thermal power of fuel and require more detailed cleaning of the ember tray (of non-burned material) and combustion chamber.

! Special attention should be paid to storage and moving of the sacks with pellets. One should avoid its breaking and making of splinters.

If splinters are put in the storage of the stove, it could cause blockage of the system of pellet loading.

3.3. DESCRIPTION OF MAIN PARTS OF THE STOVE

- A) **Pellet storage**
- B) **Door with a handle**
- C) **Combustion chamber**
- D) **Ashtray drawer**
- E) **Control panel**
- F) **Ember tray**
- G) **Fan for heating up the space**

It is placed in the lower part of the stove. It is automatically moved when the body of the stove is heated and is automatically extinguished when it is cooled down.

- H) **Smoke expulsion fan**

It enables aggressive smoke expulsion and simultaneous intake of the air which is combusted in the ember tray. It works parallel with the system for loading and exchanges the power for smoke discharge in dependence of the thermal power.

- I) **Thermostat for manual pellet loading**

- L) **Pressure switch (pressostat)**

- M) **Thermostat for manual boiler loading**

- N) **Loading System**

It consists of the regulator and dispenser and enables pellet to fall in the ember tray.

- O) **Electronic small board**

- P) **Stove ignition switch**

- Q) **Electronic lighter**

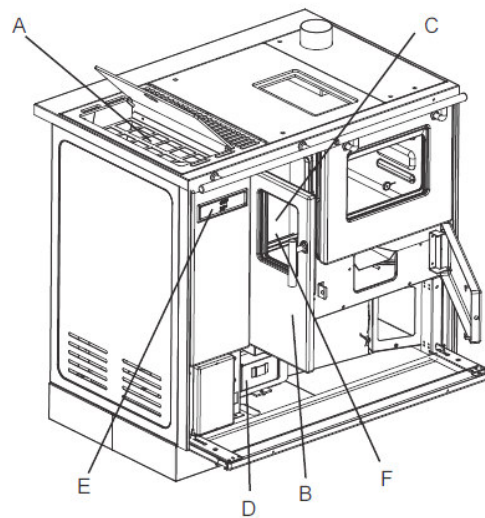

Fig. 3.3.1

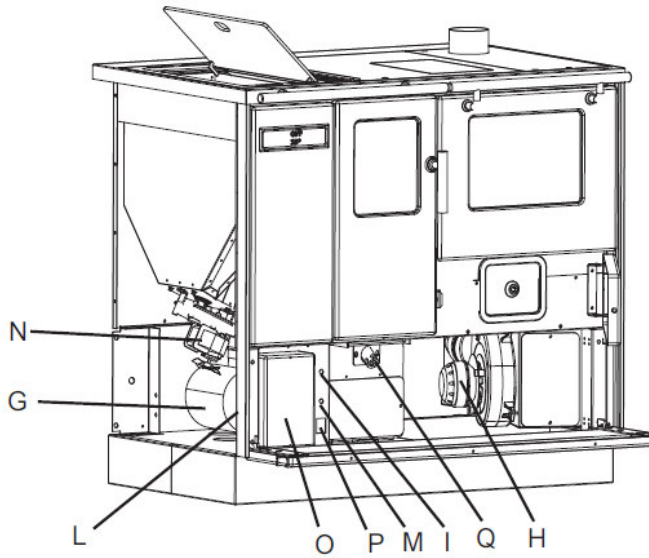

Fig.3.3.2

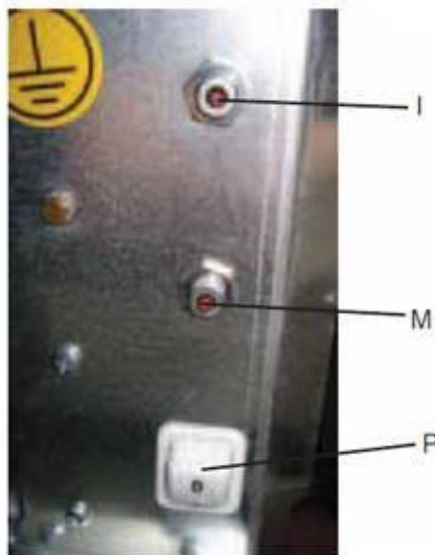

Fig. 3.3.3

4 DELIVERY AND TRANSPORT

The stove is delivered with all the associated parts.
Be careful – the stove has a tendency to turnover.

! **Centre of gravity of the stove is moved to the left.**

Take care of the above stated even in case of the moving of the stove.

During lifting avoid difficult moves.

Make sure that the fork lift truck has a bigger carrying capacity than the weight of the stove it should lift.

The operator of the fork lift truck shall be the only person responsible for the lifting of the weight.

! **Make sure the children do not play with parts of the packaging material (e.g: cellophane and polystirol)**

Danger of suffocation!

5 PREPARING THE SPACE FOR INSTALLATION

5.1 PRECAUTION MEASURES

! It is the user who shall bear and keep the responsibility for the operations conducted in the space in which the stove shall be installed and he/she is

entrusted to carry out the checks in regard to the proposed installation

The user is to comply with all the local, national and European safety regulations.

Stove must be installed on the floor of the appropriate capacity.

Instructions for assembly and disassembly of the stove are only intended for specialized technicians.

Advice to users is to always address our technical assistance with the request for qualified technicians.

In case of recruitment of other technicians, it is recommended that you check their actual abilities.

Before beginning with the phase of assembling or disassembling of the stove, the installer, has to apply security measures provided by law, in particular he is :

- A) not to operate in the conditions hampering him in his work;
- B) to work in perfect mental and physical conditions and make sure that the means for the personal protection are complete and in good condition;
- C) to wear protective gloves;
- D) to wear protective shoes ;
- E) to use tools with insulation against electric shock;
- F) to make sure that the space in which assembly or disassembly is performed is freed from obstacles.

5.2 GENERAL MEASURES

There are many factors that influence the effectiveness of fire - in terms of thermal performance and low emission of pollutants (CO - carbon monoxide).

Some factors depend on the stove, but some depend on the characteristics of the space, installing and the extent of regular maintenance of products.

Some of the important factors are:

- air that is used for combustion;
- Characteristics of the drainage system for the products of combustion;
- The quality of pellets (moisture content and dimensions).

The following paragraphs lay down certain guidelines that should be followed in order to achieve the best performance of the purchased products.

5.3 PLACE OF INSTALLING THE STOVE

Picture (Fig. 5.3.1) shows a minimum distance that must be allowed for when setting up the stove in the regard of the materials and flammable objects.

- A) Adjoining wall**
- B) The wall behind the stove**
- C) The side wall**
- D) Protection of the floor**

Protect from the flame heat radiation all the things that could ignite if exposed to excessive heat.

Wood floors or those made of combustible materials must be protected with non-combustible material, such as sheet metal of 2-3 mm thickness

Protection must cover the entire floor area in front of the stove.

The stove can be installed between two walls..

Minimum space that should be allowed between the stove and the wall surfaces should be 2 cm.

Any wooden beam placed over the stove must be protected by refractory material.



If the above stated conditions are not fulfilled, the stove cannot be installed.

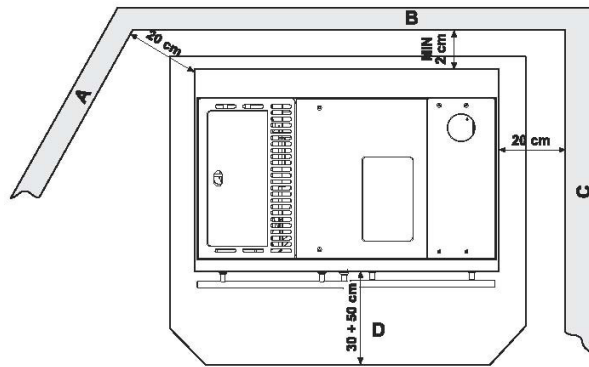

Fig.5.3.1

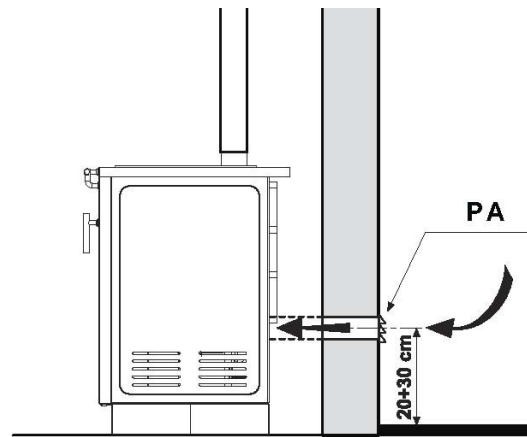

Fig.5.4.1

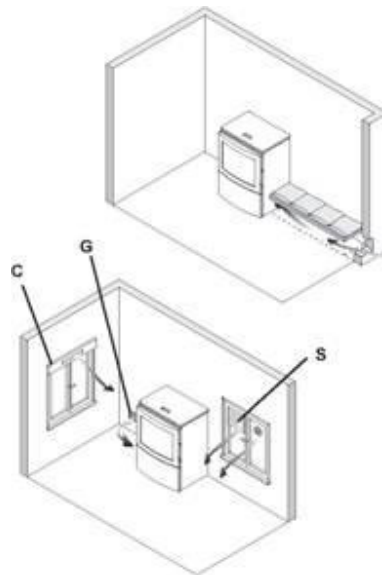

Fig.5.4.2

5.4 AIR USED FOR COMBUSTION



The stove, during its operation takes the air from the room in which it is located through the hole located on the rear right side of the stove.

The place for taking air from outside can be linked with a hole in the wall by means of the pipe with a gasket, whose diameter is 80 mm.



The maximum length of the air intake pipe is 4.5 m with a maximum of 3 cranks with an angle of 90°.

Air inlets should be placed at a height of 20-30 from the soil.

From the outside, a grid must be placed for permanent ventilation, in very windy areas exposed to rain and wind, protection must be provided from rain and wind.

If it is impossible to provide the room with outdoor air, it is possible to make an external opening in the adjoining room, but constant communication with the transit grid must be provided. The stove configured in this way is no longer hermetically sealed in regard to the room in which it is installed (Fig. 5.4.2 - C = Crate, G = grid, S = shade).

! **It is forbidden to take the air out of the garage, storage with flammable materials or areas where there is a risk of fire.**

! **If there are several other heaters in the area and the stove is not hermetically sealed in the space where it is installed, the access to the air supply must be guaranteed for the amount of air necessary for the operation of all appliances.**

! **If in the area where the stove is set, one or more fans for air expulsion (aspirator) is working, it is necessary to check that there is no poor performance of the stove caused by the insufficiency of air needed for combustion**

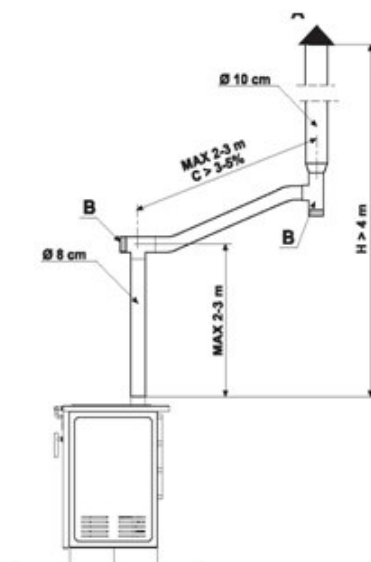

A – Chimney cap
B – Checking
C – Acclivity
H – Height

Fig.5.5.1

5.5 SMOKE EXPULSION

! **The stove works with combustion chamber in depression and therefore it is absolutely necessary to check if the smoke discharge channel is hermetically closed.**

- After choosing the appropriate place for installing and after having in mind the above stated measures in paragraph 5.3, the place for the smoke discharge pipes should be determined.

- The pipes which should be used must be stiff, made of aluminium tin (at least 1,5 mm thick) or made of stainless steel (at least 0,5 mm thick) with nominal diameter of 8 cm and with the gaskets (up to 5 meters long) or up to 10 cm with gaskets (over 5 meters long) (Figure 5.5.1)

It is advised that the pipes should be isolated with isolation material (glass

wool of minimal thickness of 2 cm) or steel pipes with double layer should be used, whereas, possibly, the vertical part, if internal, does not have to be double-layered.

! - It is mandatory that the first vertical part should be at least 1,5 meter long so as to guarantee regular smoke discharge.

It is desirable to make up to 5 to 6 changes of directions of the crank up to 45-90° or T joints.

- Always use T joints with access eyes at each horizontal and vertical change pipe direction.

- Horizontal parts must not be longer than 2-3 m with acclivity of 3-5%.

- Anchor the pipes to the walls.

! **Pipe joint MUST NOT BE CONNECTED**

- **On the chimney used by other smoke generators (stoves, fireplaces, etc.)**

- **On the system for air extraction (aspirators, valves, etc.) even if connected to tubes.**

! **It is forbidden to install the valves to turn off the draft.**

! **For the pipe length of over 5 meters or in low draft conditions (the presence of many curves, inadequate endings of discharge channel, etc.) it could happen that the smoke discharge is not appropriate.**

In that case it will be necessary to modify the parameters of work (discharge of smoke and pellet loading) so as to comply with the real characteristics of the chimney.

Contact technical support.

5.5.1 Chimney for smoke discharge must be made with respect to the regulations in terms of dimensions, and in terms of materials used for its production.

COLLAPSED chimneys, made of unsuitable material (fiber cement, galvanized steel, etc. whose interior is smooth and porous) are illegal and call into question good functioning of the stove.

Smoke discharge through a traditional chimney (Figure 5.5.1) can be done only if the following rules are observed:

- Inspect the state of the chimney; in case of the old chimney, it is advisable to carry out its sanitation by importing of steel pipes insulated in the proper manner (steel wool, vermiculite).

- Smoke can be extracted directly into the chimney which is equipped with the access eye.

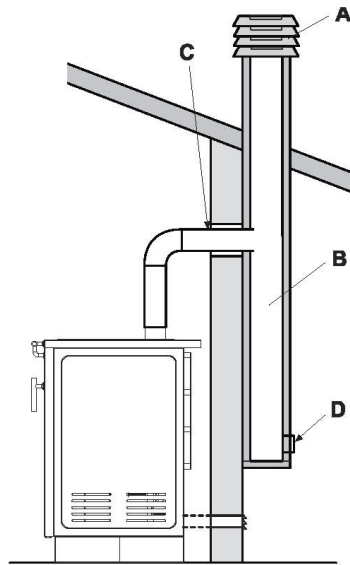

Fig.5.5.4

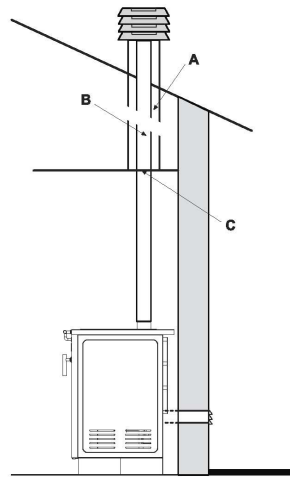

Fig.5.5.5

- A) Wind damper
- B) Chimney
- C) Hermetic sealing
- D) Access eye

! - In the case of a larger diameter chimney, it is necessary to "insert" in the same a steel pipe (with a diameter that corresponds to the chimney) and is isolated in an appropriate manner (Figure 5.5.1-2).

- Make sure the connection to the chimney in the wall is well sealed.
- Avoid contact with combustible material (wooden beams) and in any case take care of their insulating with refractory material.

- A) Vermiculite and/ or glass wool.
- B) Steel pipe.
- C) Cover panel.

6 INSTALLATION

Installation must be performed by qualified personnel with respect to regulations.

6.1 CONNECTING THE APPLIANCE

6.1.1 Connection to electricity

Just plug the stove using the supplied plug.

☞ Connecting to electricity (plug) must be easily accessible even after stove installment.

! If the supply cord is damaged, it must be replaced by technical assistance staff or by qualified technicians in order to avoid any risk.

6.1.1.1 **Grounding**

! It is mandatory to perform grounding and set up the differential switch in line with the applicable laws (Figure 6.1.1).

! **The metal chimney must have its own proper grounding.**

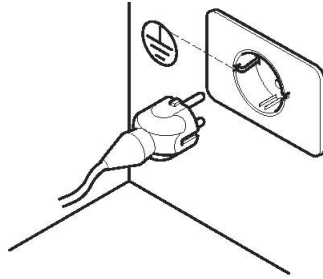

Fig. 6.1.1



Fig. 6.1.2

6.1.1.2 **Stove start-up**

To put the stove into operation put the switch to "I" (ignition) (Figure 6.1.2)

7 **START-UP AND USE OF STOVE**

7.1 **Loading pellet**

The first operation that needs to be done in order to light the stove is to fill the repository with fuel (pellet).

! **Pellets to be poured into the repository with the blades (Figure 7.1.1). Do not empty the bag directly into the repository.**



Fig.7.1.1

7.2 DESCRIPTION OF CONTROL PANEL

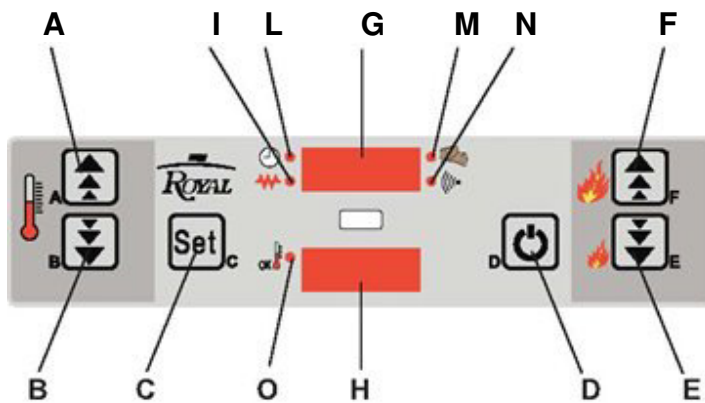

FIG.7.2

The control panel consists of two LCD displays with backlight, **ON / OFF (D)** keys, the key to set the operation **MENU (C)**, four menu buttons **A, B, E, F** and 6 LEDs that display the state of functioning the stove.

The panel allows the stove on and off, regulates its operation and allows adjustment of the management and maintenance programs.

Key:

- A** = Increasing the temperature
- B** = Decreasing the temperature
- C** = Menu set up – Verifying the parameters
- D** = On/Off
- E** = Decreasing power
- F** = Increasing power
- G** = State of display / power / parameter name
- H** = State of display / clock / temperature / parameter value
- I** = LED resistance ON

- L** = LED – activated timer
- M** = LED – coil operation
- N** = LED – deactivation
- O** = LED – room thermostat

To **access** the menu:

- 1) Press the **menu** key (**C**).
- 2) Press the **menu** key (**C**) several times to browse different menus.

The display **G** will show Set/parametro (Settings/parameter).

The display **H** will show temperature or parameter value.

In order to confirm the values of the parameters, press the **menu** key (**C**).

7.3 STURT-UP PHASE

7.3.1 Electrical power

Connect the stove to the power grid by setting the ignition switch to position “I” (paragraph 6.2).



FIG.7.3.1

If the connection is done correctly, the display is switched on and “OFF” appears on the label furnished clock (Figure 7.3.1).



The stove operational parameters can be set only in the phase of work.

7.3.2 START-UP PHASE (ignition)

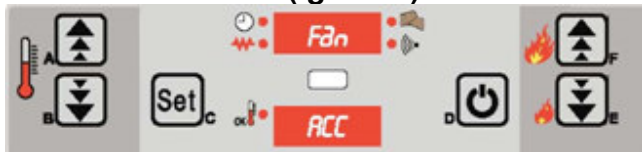

FIG.7.3.2

To light the stove, hold **On/Off (D)** for a few seconds.

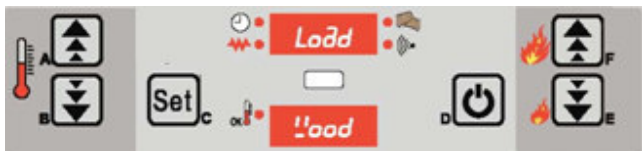

FIG.7.3.3

The display will show captions “Fan” and “ACC” (ignition).



FIG.7.3.4

This phase is automatic and the stove operates it completely, so it is impossible to modify any parameter (Figure 7.3.2).



Fig.7.3.5

The coil for loading pellets is powered. Starting the coil is marked by turning LED (M).



Fig.7.3.6

The display will show captions "Load" (loading) and "Wood" (wood).

Automatic ignition: the stove is equipped with an automatic device that allows the burning of pellets without the use of other traditional means of ignition.

When the flame lights up, the stove starts to work.

The display will show the caption "Fire" and "on".



! When the stove is new (or when, however, the repository is completely discharged), the ignition may not occur because the coil for loading pellets takes a few minutes to fill and supply the ember tray.

To solve the problem, just pour a handful of pellets in the ember tray before you press the key ON.

In the case of poor performance or improper burning pellets in the ember tray, the ignition alarm will start.

The display will show the captions "Alarm" and "ACC" (ignition).

Chapter **Alarms** will explain the procedure to unblock the stove.

7.4

PHASES OF WORK

On completed ignition, the display will show the adjusted power and room temperature.



FIG.7.4.1

Example: the display will show the captions "on 1" and "17°C".

During this phase, the cooker is automatically adjusted depending on the values configured for the power, speed of the air exchanger and the value of room temperature that was set during the last ignition.

At this point, if necessary, operating parameters are subject to change.

THE STOVE POWER (the value set between 1 i 5).

Defines the power at which the stove works (Figure 7.4.2).



FIG.7.4.2

Press the keys (E) and (F) to increase or decrease the power. After three seconds, the values will be automatically saved.

ROOM TEMPERATURE (the value between 7°C and 41°C)

Defines the desired room temperature.

For example: the display will show the captions “SET” (settings) and “20°C”.



FIG.7.4.3

Press the keys (A) and (B) to increase or decrease the temperature. After three seconds, the values will be automatically saved.

AIR SPEED (the value between A, 1-5)

Defines the speed of the air exchanger.

Press the key (C) until the parameter starts flashing.



FIG.7.4.4

The display will show the caption “SET 2” (setting 2).

Press the keys (E) and (F) to increase or decrease the temperature. After three seconds, the values will be automatically saved.

Pressing the “SET A” (setting A) fan speed is automatically adjusted to the adjusted power (ADVISED).



Set values will remain until the next changes, even though the stove is switched off or turned off the power.

ROOM TEMPERATURE DISPLAY

To display the preset room temperature, press the key (C).



FIG.7.4.5

After two seconds, the room temperature will be displayed.

ROOM TEMPERATURE REACHES THE PRESET TEMPERATURE

When the room temperature reaches a preset value, the **POWER** is automatically put to a minimum.



FIG.7.4.6

Example: the display will show the captions “ECO” and “22°C”.

LED – room thermostat (O) is switched on.

BAKING IN THE OVEN

The advised power for baking in the oven is P4.

The pan can be placed at different heights based on the type of food that is baked.

To bake cookies, set the rack at an intermediate level, but for cakes and chops, set the rack on the lower level.

The power P5 should only be used for heating or cooking food on the rack set on the upper level.

7.5 SWITCHING OFF

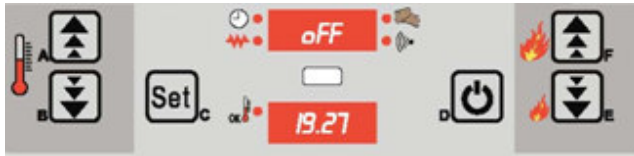

FIG.7.5.1

To switch off the stove, hold the key **On/Off (D)** for a few seconds.
 Example: the display will show the captions **“OFF”** and **“19.27”**.

The coil for loading pallets will stop immediately while the fan will be automatically switched off when the stove cools down.



To re-light, it is necessary to wait for the stove to cool down completely.

In the case of trying re-ignition while the stove is not fully cooled down, the display will show captions **“OFF”** and **“Atte”** (wait) to invite the user to wait for complete termination.



FIG.7.5.2

! Do not pull the plug to turn off the stove. Let the cycle be completed. Prolonged operation of smoke extraction fan is normal.

7.6 ADVANCED USE OF CONTROL PANEL

This chapter will describe and review the advanced use of stoves, such as programmed ignition and automatic extinction.

1) Press the key **menu (C)**.

7.6.1 Clock

2) Select **“UT01” GIORNO** (day) – the values between **OFF**, **Day1** and **Day7**



FIG.7.6.1

3) Select the day by pressing the keys **(A)** and **(B)**.

4) To confirm selection, press the key **menu (C)**.

5) Press the key **“UT02” ORA CORRENTE** (current hour) – the values between **00.00** and **23.00**



FIG.7.6.2



FIG.7.6.3

- 6) Select the hour by pressing the keys (A) and (B).
- 7) To confirm the selection, press the key menu (C).
- 8) Press the key “UT03” **MINUTO CORRENTE** (current minute) – the values between **00** and **60**.
- 9) Select the minute by pressing the keys (A) i (B).
- 10) To confirm the selection, press the key **menu(C)**.

7.6.2 Timer

Automatic ignition and extinction of the stove is programmed through this menu. To access programming parameters, it is absolutely necessary to set the parameter “UT01” opposite of **OFF**.



FIG.7.6.4

Timer function is activated when the parameter “UT01” is set to the current day of the week. When the clock is activated, the LED “L” turns on.

The selection is automatically saved when proceeding to the next parameter.

It is possible to set a four-stage ignition and extinction: **Programme 1**, **Programme 2**, **Programme 3** and **Programme 4**.

Programme 1 is defined by parameters **UT05** (ignition hour), **UT06** (extinction hour), **UT07** (ON-OFF day).

Programme 2 is defined by parameters **UT08** (ignition hour), **UT09** (extinction hour), **UT10** (ON-OFF day).

Programme 3 is defined by parameters **UT11** (ignition hour), **UT12** (extinction hour), **UT13** (ON-OFF day).

Programme 4 is defined by parameters **UT14** (ignition hour), **UT15** (extinction hour), **UT16** (ON-OFF day).

Within the parameters **UT05**, **UT06**, **UT08**, **UT09**, **UT11**, **UT12**, **UT14** and **UT15**, pressing the keys (A) and (B), the clock is adjusted by increasing or reducing it, with the transition of 10 minutes, and the hour is displayed on the lower display (H).

Parameters **UT07**, **UT10**, **UT13** and **UT16** define ignition and extinction on different days.

Pressing the key (A) the status of individual days is displayed.

Pressing the key (B) daily programme from (on1/off1) to (on7/off7) is activated or deactivated.

EXAMPLE

If you want to light the stove at these hours:

Monday	6.30 - 20.30
Tuesday	5.00 - 22.00
Wednesday	6.30 - 20.30

Thursday	6.30 - 22.00
Friday	6.30 - 22.00
Saturday	8.00 - 20.00
Sunday	8.00 - 20.00

You have to set the parameters as follows:

- UT05 6.30, UT06 20.30, UT07 (on1, off2, on3, off4, off5, off6, off7)
- UT08 5.00, UT09 22.00, UT10 (off1, on2, off3, off4, off5, off6, off7)
- UT11 6.30, UT12 22.00, UT13 (off1, off2, off3, on4, on5, off6, off7)
- UT14 8.00, UT15 20.00, UT16 (off1, off2, off3, off4, off5, on6, on7)

7.7 ALARMS

If the anomaly is found in the work, the following process is initiated:

- 1) loading pellets is blocked
- 2) smoke extraction fan is strongest

To be able to re-light the stove, it is necessary to wait for the stove to cool down completely, and then press the key “D” (on / off).

If the stove is not cooled down, “OFF Atte” is displayed (Off Wait).

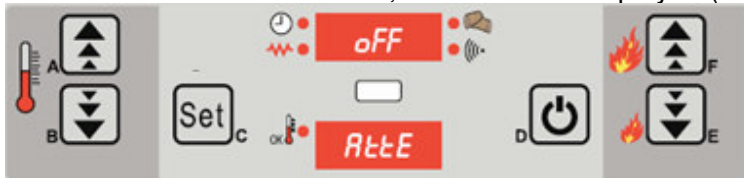

FIG. 7.7

A variety of alarm messages that may appear on the display are listed below.

7.7.1 Alarm ALAr ACC (ignition alarm)

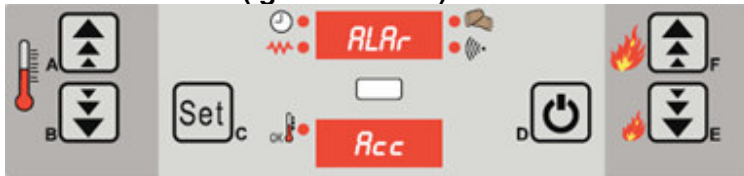

FIG. 7.7.1

It appears when the burning was unsuccessful and the message “ALAr ACC” (ignition alarm) is displayed.

The process of extinction is immediately activated.

7.7.2 Alarm Cool FirE (alarm to stop the electric power)

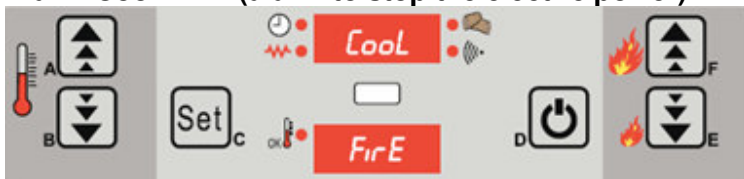

FIG. 7.7.2

It appears when the voltage interruption in the network occurs.

Upon returning to an earlier state, the message “Cool FirE” (alarm to stop the electric power) is displayed and the stove waits until the smoke temperature returns to normal.

At this point, the normal operation cycle starts again.

7.7.3 Alarm ALAr Sond (alarm for the smoke probe)



FIG. 7.7.3

It appears in the case of a failure or turning off the probe for smoke detection.
For the duration of the alarm, the stove performs the extinction operation.

7.7.4 Alarm ALAr dEP (alarm for depression)

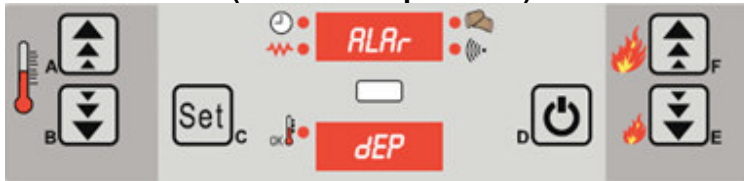

FIG.7.7.4

It appears when there are irregularities related to:

- chimney draft, i.e. insufficient depression

If the alarm does not go out, check to see if the stove or chimney must be subjected to maintenance operations.

7.7.5 Alarm ALAr PELL (alarm for pellet temperature)



FIG.7.7.5

It appears when the temperature of the pellet probe is too high.

To return the stove to normal operation, wait for the stove to cool down.

7.7.6 Alarm ALAr FAn (alarm for the air induction fan)



FIG.7.7.6

It is activated when there is an irregularity in the work of the smoke fan.

For the duration of the alarm, the stove performs the extinction operation.

7.7.7 Alarm ALAr hot (alarm for the high smoke temperature)

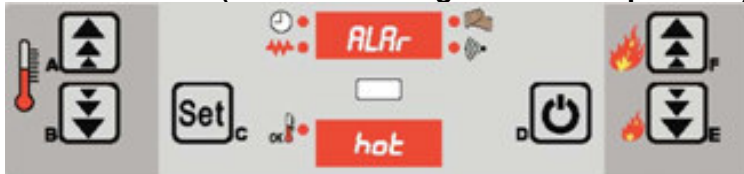

FIG.7.7.7

It appears when the probe detects the smoke temperature is too high.

7.7.8 Alarm ALAr FirE (alarm for the extinction during the phase of work)

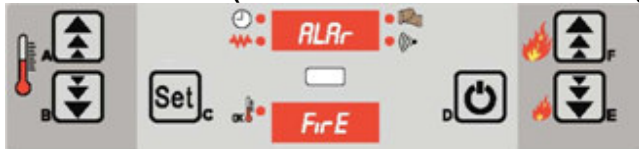

FIG.7.7.8

It is displayed during the phase of work if the flame extinguishes, and the smoke temperature falls below the minimum level of operation.

The extinction procedure is currently activated.

7.7.9 Alarm ALAr Sic (alarm for the main thermostat)



FIG.7.7.9

It is displayed when the main safety thermostat detects temperature higher than allowed.

7.8 A message “ALarSic” (safety alarm) is displayed and the system stops. -
CLEANING EMBER TRAY

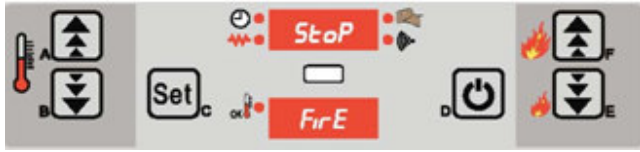

FIG.7.8.1

It may be that during normal stove operation, at certain intervals, the message “Pulizia Braciera” (CLEANING EMBER TRAY) is activated.

The message “**StoP FirE**” is displayed.

8 MAINTENANCE AND CLEANING
8.1 SAFETY MEASURES

! Before undertaking any maintenance operation, apply the following safety measures:

- A) Make sure all parts of the stove are cold.
- B) Make sure the ember is completely extinguished.
- C) Use means of personal protection specified by the Directive 89/391/CEE.
- D) Make sure the main electrical switch is off.
- E) Make sure there can be no power supply. Pull out the plug.
- F) Always use the right tool for the maintenance of the stove.
- G) When the maintenance or repair operations are completed, and before putting the stove into operation, reset all the protections and activate any protective devices.

8.2 REGULAR MAINTENANCE BY THE USER

8.2.1 Interior cleaning of furnace

The stove requires a simple, but often careful cleaning in order to guarantee efficient performance and proper operation.

! **Perform cleaning when the stove is cold.**

EVERYDAY CLEANING

Remove the ashes that are deposited inside the furnace (Figure 8.2.1-1)



FIG.8.2.1-1

The aim of this cleaning is to enable free flow of the air burning from the holes of the EMBER TRAY. The use of a vacuum cleaner can simplify cleaning ashes. Use the device that has a densely-woven filter to avoid:

- re-release of the sucked ashes into the air;
- breaking the vacuum cleaner due to suction of particles of certain sizes.

PERIODIC CLEANING

Perform complete periodic cleaning of the furnace by removing the ember tray. (Figure 8.2.1-2).



FIG.8.2.1-2

Clean the smoke extractor by removing panels from the baking plate (Figure 8.2.1-3).



FIG.8.2.1-3

Clean the area for extracting smoke (Figure 8.2.1-4).

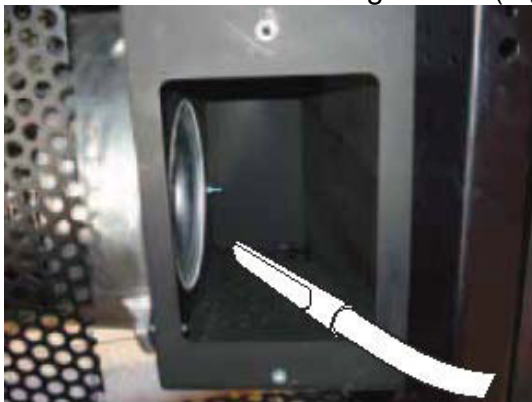

FIG.8.2.1-4

Clean the area where the precipitation remains below the oven (Figure 8.2.1-5).



FIG.8.2.1-5



The presence of condensation is an indicator of possible infiltration of water or over-cooling of smoke. It is advisable to determine the possible reasons in order to enable the stove to work properly again.

8.2.2 Cleaning ashtray

Cleaning the ashtray is done once a week or as needed.

To reach the ashtray, open the door in front of the ashtray. Remove the ashtray (Figure 8.2.2.1). Empty the ashtray.

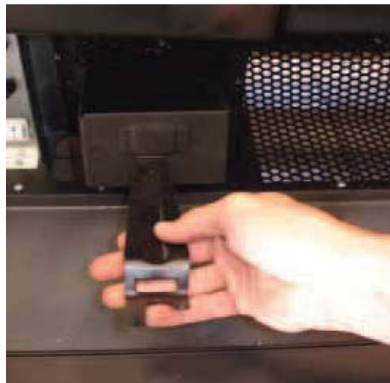

FIG.8.2.2-1

Vacuum up any remains from the space containing the ashtray.

Put the ashtray back into place and close the door.

8.2.3 Glass cleaning

The glass is cleaned with a damp cloth or wet paper.

Rub until the glass is cleaned.

Detergents for cleaning the kitchen ovens can also be used.

Do not clean the glass while the stove is working and do not use abrasive sponges.

Do not wet the gasket around the door because it can fail.

8.2.4 Chimney cleaning

Cleaning should be done at least twice a year, at the beginning and in the middle of winter period, i.e. whenever necessary.

If there are horizontal components, it is necessary to check and remove possible residue of ash and soot before they shut up the passage of smoke.

If the chimney is not cleaned, the following problems may occur:

- bad combustion;
 - glass browning;
 - clogging of the ember tray due to deposition of ashes and pellets;
 - deposition of ashes and excessive deposition on the exchanger, which leads to poor performance of the stove.
- A) Valve against the wind (Figure 8.2.4-1)
- B) Access eye (Figure 8.2.4-1)

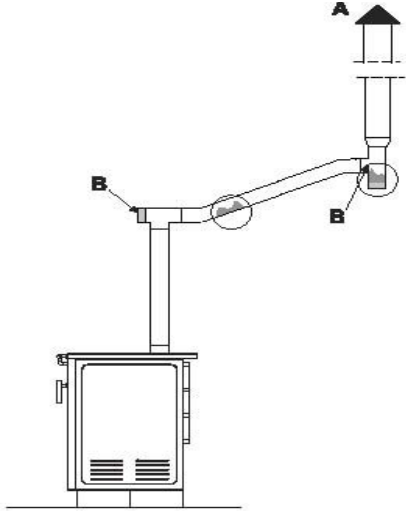

FIG.8.2.4-1

9 INFORMATION ON THE DESTRUCTION AND TRANSPORT TO LANDFILL

Destruction of the stove and its transport to landfill is the exclusive responsibility of the owner who must apply the applicable laws of his country related to safety, respect and preservation of the environment. Destruction and transport to landfill can be delegated to a third party, but authorized companies should always be contacted for takeover and destruction of the specified material.



INSTRUCTION *always comply with applicable regulations of the country where the stove is installed for the destruction of the material and possible destruction reports*

! ATTENTION *All the operations of dismantling the stove for its destruction must be performed on the stove that is unplugged.*

- take out all electrical components;
- separate batteries stored on electronic pads;
- destroy the stove through an authorized company

! ATTENTION *Leaving the stove on inadequate site presents a great danger to humans and animals.*

Responsibility for any damage to humans or animals is at the expense of the owner.

When the destruction of the stove is performed, the CE marking, this manual and other documents in connection with the stove must be destroyed.

10 ELECTRICAL SCHEMES

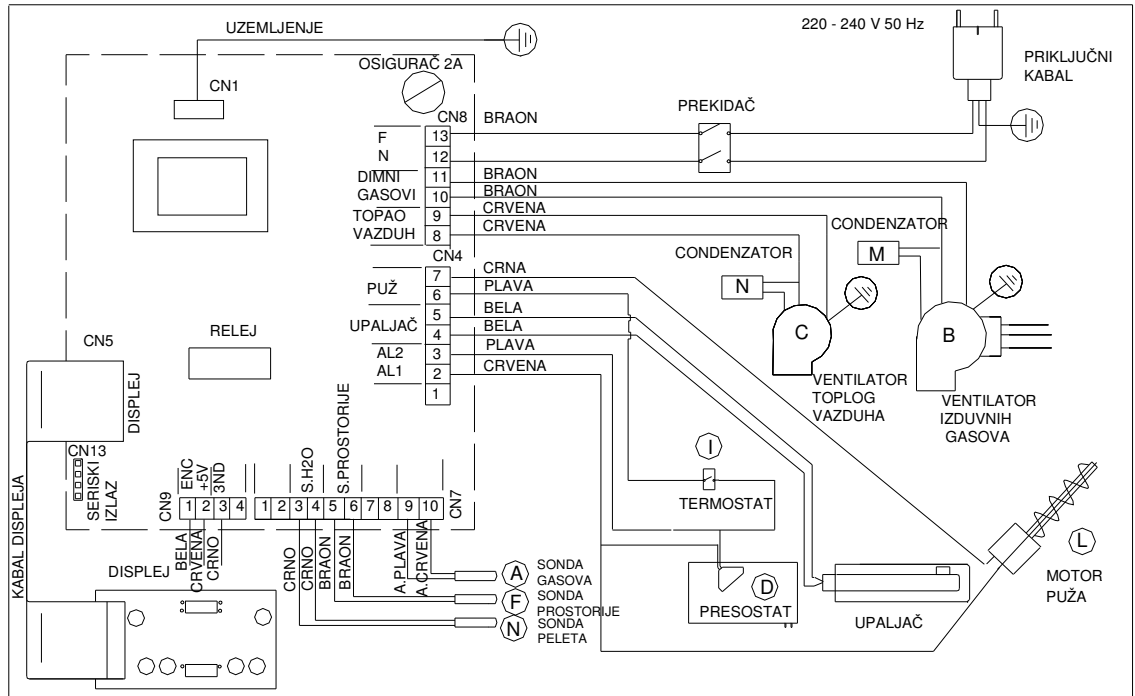

SCHEME FOR ELECTRICAL INSTALLATION

C	N1	EARTHING
CN4		D)...	PRESSURE CONTROL(2) Red – (3) Blue
		LIGHTER (4) white – (5) white
		L)....	LOADING COIL (2) red – (7) black
		I)....	THERMOSTAT (3) Blue – (6) Blue
CN5		CONTROL PANEL
CN7		A) ...	SMOKE PROBE (9) Blue (-) – (10) Red (+)
		F) ...	ROOM TEMPERATURE PROBE (5) Brown – (6) Brown
		N) ...	PELLETE PROBE (3) Blue – (4) Blue
CN8		B) ...	SMOKE EXTRACTION FAN (10) Brown – (11) Brown
		C) ...	EXCHANGER FAN (8) Red – (9) Red
		M) ...	CONDENSER
		N) ...	CONDENSER
		FN) .	POWER SUPPLY 230 V 50 Hz (12) Blue – (13) Brown
C	N	B) ...	SENSOR "HALL" (1) White – (2) Red – (3) Black
C	N	SERIAL OUTPUT

HOME PLATE LEGEND

SYMBOL	
F	Fuel
P _{max}	Nominal thermal power to room
P _{min}	Reduced thermal power to room
P _{wmax}	Nominal power to water
P _{wmin}	Reduced power to water
p	Maximum operating pressure
EFF _{max}	Nominal effect
EFF _{min}	Effect with reduced power
CO _{max} (13% O ₂)	CO emissions at nominal power (13% O ₂)
CO _{min} (13% O ₂)	CO emissions at reduced power (13% O ₂)
d	Minimum distance from combustible materials
V	Voltage
f	Frequency
W _{min}	Minimum absorbed power during operation
W _{max}	Maximum absorbed power on ignition
	Stove may not share a chimney with the other appliance
	Read and follow the instructions for use and maintenance
	Use only recommended fuel
	Stove can work with interruptions

TECHNICAL SPECIFICATIONS

	Power	
	Reduced	Nominal
Global thermal power (effect)	2236 kcal/H 2.6 kW	6966 kcal/h 8.1 kW
Effect	86,2 %	86%
Smoke temperature	106°C	207°C
Smoke volume	5.1 g/s	1.36 g/s
Fuel consumption per hour	0.64 kg/h	1.98 kg/h
CO emission (with 13% O ₂)	594 mg/Nm ³	97 mg/Nm ³
Smoke output	Ø 8 cm	
Air intake pipe	Ø 10 cm	
Weight	180 kg	
Fuel	Pellets	
Feed tank capacity	Max ~ 15 kg	
Chimney draft	12(±2) Pa	
Heating area	70 m ²	

Stove intended for the area not smaller than	40 m ²
--	-------------------

REQUIREMENTS ON ELECTRICAL POWER	
Voltage	230 V
Frequency	50 Hz
Maximum absorbed power during operation	110 W
Absorbed power on ignition	400 W

DIMENSIONS

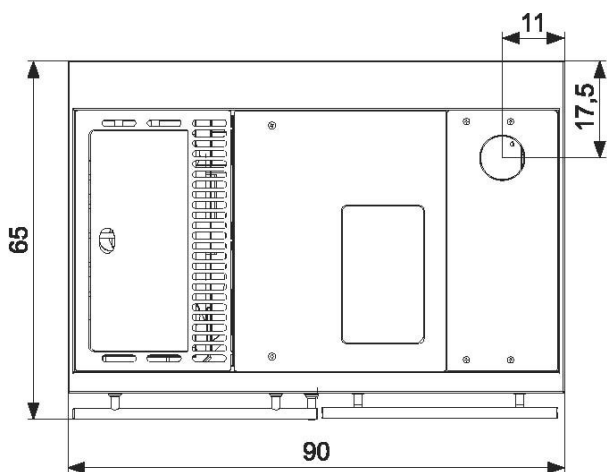
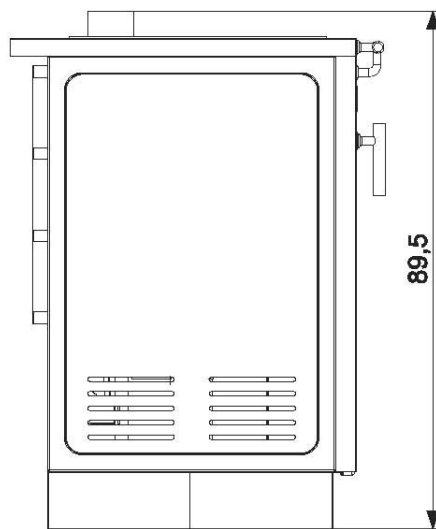
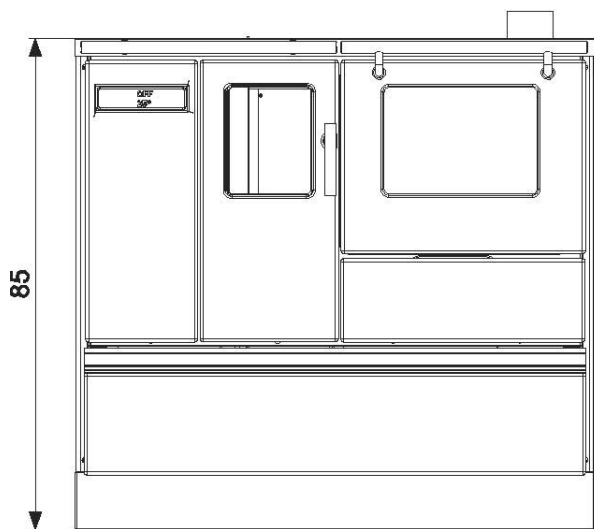

Minimal dimension that is variable depending on setting the pins

Dimensions (cm)

TIME OF GUARANTEED SERVICING

This implies the period during which we guarantee the service, accessories and space parts, starting from the day of purchase of the device.

The time of guaranteed servicing is in accordance with the valid legal regulations.

In case of change of the model and the design of the device, the term for change of parts that have modified design is within the legal term.

After this term we provide the modified parts in the new designs.

CONDITIONS OF THE GUARANTEE

The guarantee of the product is valid within the legally defined term.

The guarantee is not valid for the glass, the glass-ceramic panel and the physical damages that have occurred after purchase.

THE MANUFACTURER RETAINS ALL THE RIGHTS TO MAKE CHANGES.

The device will properly function within the guaranteed term only if it is used in accordance with these guidelines for connection and application.

The guarantee cases to apply if it is determined that:

- the connection or the repair of the product was performed by an unauthorized person, that is, if unoriginal parts have been embedded,
- if the device has not been properly used in accordance with these guidelines,
- if some mechanical damaging of the device occurred during usage,
- if the repairs of defects were performed by an unauthorized person,
- if the device has been used for commercial purposes,
- if the damage has occurred during transportation after the device was sold,
- if the defects occurred due to improper mounting, improper maintenance or mechanical damaging by the buyer,
- if the defect occurred after too strong or insufficient power, as well due to force major.

We can repair the defects of Your device also outside the guaranteed period, with original spare parts for which we also provide a guarantee under the same conditions.

This guarantee does not exclude or affect the rights of the customer in regard to the conformity of the goods pursuant to the legal regulations. If the delivered product does not conform to the agreement, the customer has the right to ask the seller to repair that lack of conformity without any reimbursement, by repair or change of the product in accordance with the valid legal regulations.

Alfa plam company assumes no responsibility for any errors in this manual and is free to amend the characteristics of its products without prior notification to customers.

ALFA PLAM

“ALFA PLAM AD”

1 Radnička St.

17500 Vranje-Serbia

Phone No. 017/421 121

Fax 017/424 808

Internet:

E-mail: